

SUMEC FIRMEN

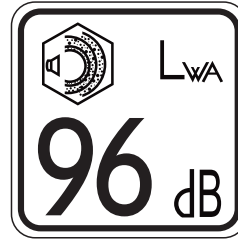

OWNER'S MANUAL

Degree of protection: IP23



Gasoline Engine Generator



TABLE OF CONTENTS

Safety information	1
Safety and operation rules	1
Electrical safety	4
Leakage current	4
Selecting a generator	7
Wattage calculation	7
Typical equipment requirements	8
Electric motor loads	8
Operating voltage	9
Installation	10
Extension cord	11
Line transfer switch	11
Pre-operation check	12
Grounding	12
Lubrication	13
Engine oil recommendation	13
Low oil warning system	13
Fuel recommendations	13
Start the unit	15
Pre-start preparation	15
Start the engine	15
Applying load	16
Shutting the generator off	16
Break-in procedure	17
Maintenance	18
Daily inspection	18
Periodic inspection	18
Inspecting the spark plug	19
Oil replacement	20
Air filter cleaning	20
Fuel valve filter cleaning	21
Fuel strainer cleaning	21
Generator	21
Heat shield	22
Carburetor icing	22
Quick starting tips for units that have been sitting for awhile	22
Service and storage	23
Infrequent service	23
Long term storage	23
Troubleshooting guide	24
Limited warranty	25

SAFETY AND OPERATION RULES

IMPORTANT-Please make certain that persons who are to use this equipment thoroughly read and understand these instructions and any additional instructions provided prior to operation. Warranty is voided if the customer fails to install, maintain and operate the product in accordance with the instructions and recommendations set forth in the owner's manual(s),

Due to constant efforts to improve our products, certain procedures and specifications are subject to change without notice.

SAFETY INFORMATION

DANGER

DANGER indicates a potentially hazardous situation which ,if not avoided , will result in death or serious injury.

WARNING

WARNING indicates a potentially hazardous situation which ,if not avoided , could result in death or injury.

CAUTION

CAUTION indicates a potentially hazardous situation which , if not avoided , may result in minor or moderate personal injury , or property damage.

SAFETY AND OPERATION RULES

WARNING

Failure to follow these instructions and warnings may result in severe injury or death to the engine operator ,a bystander, or person inspecting or repairing the engine or property damage.



1. Read carefully and understand operator manual prior to operation of this product. Follow all warnings and instructions.
2. Know your equipment. Consider the applications, limitations, and the potential hazards specific to your unit. Some equipment have special requirements for power supply such as frequency, voltage, AC wave shape etc.

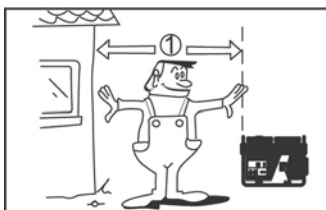

tilted, fuel spillage and bad lubrication may result.

3. Equipment must be placed on a firm, level, supporting surface. Place the generator at least 1m (3 ft) away from buildings or other equipment when operating the generator. If the generator is
4. Load must be kept within rating stated on generator nameplate. Overloading will damage the unit or shorten its life.

SAFETY AND OPERATION RULES

5. Engine must not be run at excessive speeds. Operating an engine at excessive speeds increases the hazards of personal injury. Do not tamper with parts which may increase or decrease the governed speed.

6. To prevent accidental starting, always remove the spark plug or cable from the spark plug before maintaining the generator or engine.



7. Units with broken or missing parts, or without protective housing or covers, should never be operated. Contact your service center or local dealer for replacement parts.



8. Units should not be operated or stored in wet or damp conditions or on highly conductive locations such as metal decking and steel work.

9. Keep the generator clean and free of oil, mud, and other foreign matter.

10. Extension cords, power cords, and all electrical equipment must be in good condition. Never operate electrical equipment with damaged or defective cords.



11. Store the generator in a well ventilated area with the fuel tank empty. Fuel should not be stored near the generator.

12. Your generator should never be operated under these conditions:

- a. Uncontrolled change in engine speed.
- b. Electrical output loss.
- c. Overheating in connected equipment.
- d. Sparking
- e. Damaged receptacles.
- f. Engine misfire.
- g. Excessive vibration.
- h. Flame or smoke.
- i. Enclosed area.
- j. Rain or inclement weather. Do not let the unit get wet when operating.



13. Check the fuel system periodically for leaks or signs of deterioration such as chafed or spongy hose, loose or missing clamps, or damaged tank or cap. All defects should be corrected before operation.

14. The generator should be operated, serviced, and refueled only under the following conditions:



- a. Start and run the generator outdoors. Do not run the generator in an enclosed area, even if doors or windows are open; avoid areas where vapors may be trapped, such as pits, garages, cellars, excavations and



SAFETY AND OPERATION RULES

boat bilges. **DANGER- CARBON MONOXIDE HAZARD:** The engine exhaust contains carbon monoxide , a poisonous , odorless , invisible gas which , if breathed , may cause death or serious personal injury . If you start to feel sick , dizzy or weak while using the generator , shut it off and get to fresh air right away ; you may have carbon monoxide poisoning .

- b. Good ventilation for cooling. Air flow and temperatures are important for air cooled units. Temperatures should not exceed ambient 40° C (104° F) .



- c. Refuel the generator in a well lighted area. Avoid fuel spills and never refuel while the generator is running. Allow engine to cool for two minutes prior to refueling.



- d. Do not refuel near open flames, pilot lights , or sparking electrical equipment such as power tools , welders , and grinders .

- e. The muffler and air cleaner must be installed and in good condition at all times.

- f. Do not smoke near the generator.



15. Ensure that generator is properly grounded.



16. Do not wear loose clothing, jewelry, or anything that may be caught in the starter or other rotating parts .

17. Unit must reach operating speed before electrical loads are connected. Disconnect loads before turning off engine.

18. To prevent surging that may possibly damage equipment, do not allow engine to run out of fuel when electrical loads are applied.

19. Do not stick anything through ventilating slots, even when the generator is not operating. This can damage the generator or cause personal injury.

20. Before transporting the generator in a vehicle, drain all fuel to prevent leakage that may occur.

21. Use proper lifting techniques when transporting the generator from site to site. Improper lifting techniques may result in personal injury.



22. To avoid burns, do not touch engine muffler or other



SAFETY AND OPERATION RULES

engine or generator surfaces which became hot during operation.

23. Know how to stop the generator quickly and understand operation of all the controls. Never permit anyone to operate the generator without proper instructions.

24. Keep children and pets away from the generator when the generator is running.

25. Avoid placing any flammable materials near the exhaust outlet during operation.

26. Never touch the machine with wet hands or electrical shock will occur.



Electrical safety

Every year many people injured through electrical shock. Portable, electrically operated tools account for the second largest number of injuries, with the plug or cord at fault in two-thirds of the incidents. Insurance company statistics indicates that rental equipment is involved in a high percentage of such accidents, and it is important to realized that the rental operator is liable for those defects of which he is aware, as well as those which would have been disclosed by a reasonable investigation.

Leakage current

One of the most important checks to be sure a tool is safe is for excessive leakage current. Leakage current flows from the internal wiring to metal portions of the equipment housing or enclosure.

The skin offers a barrier to the flow of leakage current. It is not until the voltage exceeds about 48 volts that a hazard exists. At a common supply voltage of 120V or 230V , current can easily pass through the skin. Once the current starts to flow, the skin resistance decreases further, allowing an increasing flow of current to pass through the body.

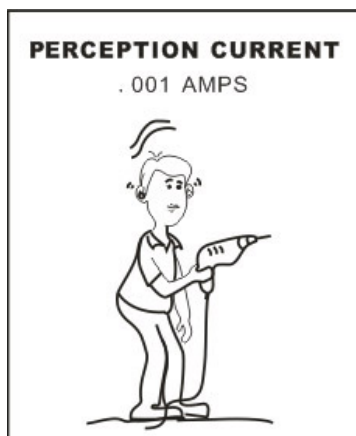

- One milliampere (1/1000 of an ampere) will be felt by most individuals as a slight tingling sensation. A defective hand drill or floor polisher might allow this amount of current to flow through a person standing on a dry wooden floor. Not bothered by it, he continues to use the equipment, until he happens to touch a water connection, heating register, metal window sash or other grounded metal object. He has now completed the circuit to ground and a much larger current will flow through his body.

SAFETY AND OPERATION RULES

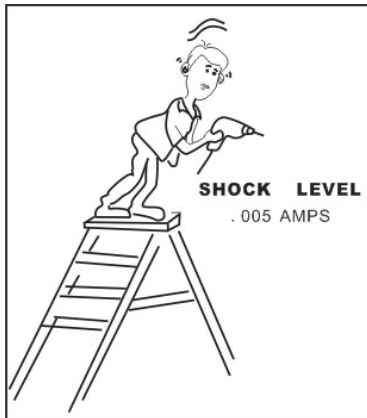

- If only five milliamperes (1/43 of the current required to operate a 25-watt lamp) flow through his body, it will result in a violet muscle reaction, throwing him away from the equipment.

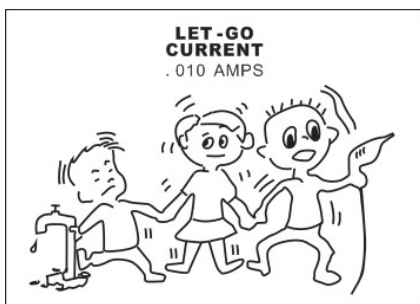

- If the current is much above 10 milliamperes, the person will lose his ability to release his grip on the electricity equipment. While the heart normally can continue to function, fatigue sets in, followed by death if no help is available.

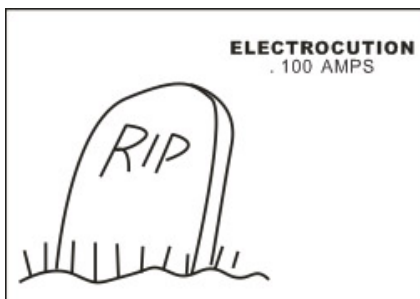

- At about 100 milliamperes (less than half that used by a 25-watt lamp) ventricular fibrillation occurs, the muscle fibers lose control and the heart is no longer able to pump blood.

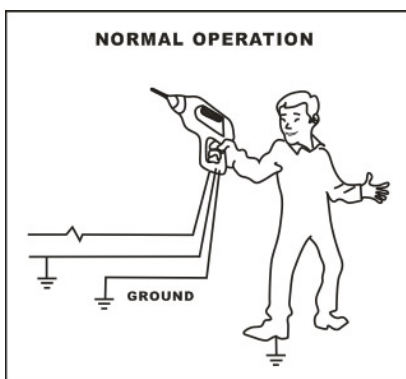

- When a tool is operating normally, electricity passes through one wire the tool and back out the second wire. Little or no current should travel down the ground wire.

SAFETY AND OPERATION RULES

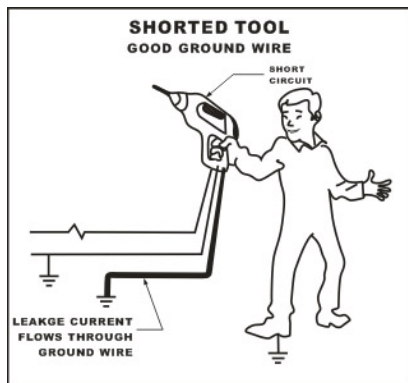

- If a tool's insulation becomes defective, some of the electrical current will pass through the tool's case to the ground wire and back to the ground. The person holding the tool will not be injured. If enough leakage current flows, the line fuse will open. The only problem is that this depends on a good ground path all the way back to the ground itself.

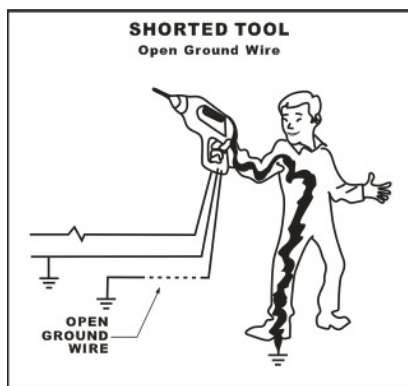

- If the ground wire doesn't make a perfect contact all the way back to the ground, the leakage current will flow through the operator to the ground. The amount of shock the person receives will depend on how defective the tool's insulation is and how well grounded the main is.

SELECTING A GENERATOR

Wattage calculation

The biggest problem in selecting a generator is determining the power requirements that must be met under operating conditions.

Under-sizing of the generator is the single most common mistake and can be avoided by considering **all** the loads to be connected to the generator . Additionally ,calculating the starting requirements of any electric motor operated equipment is a very important consideration .

An estimate of the total load that will be connected to the generator can be made by getting the nameplate amperage of all equipment or tools to be used . The nameplate , showing the electrical requirements, is found on all electric powered tools, appliances, electric motors or devices. It lists such information as running amperage, the speed at which the tool operates; hertz,or frequency; phase; and for electric motors, the code specification.

Once the total amperage draw for all tools and equipment is known, the following can be used to establish starting wattage required:

If the equipment is for heating or lighting and contains no electric motors, multiply the running amperage requirement times 1, times the voltage rating or requirement. The result will tell the wattage required for this application. Heaters , light bulbs, coffee makers, hot plates, are refered to as **resistive** loads. This type of equipment draws a constant amount of current while operating.

If the equipment to be powered consists of hand tools, such as saws, drills or other, handheld type of equipment; multiply the running amperage times 2, times the voltage requirement. Again ,the result will tell the wattage required for this application. These types of equipment typically draw twice their normal , free running amperage when used at full capacity or when starting the motor.

If the equipment being run is stationary equipment or appliances containing electric motors, multiply the running amperage times 3, times the voltage requirement. Once again , the result will tell the wattage required for this application. Electric motor driven stationary equipment typically requires up to three times the running amperage when starting, until the machine’s motor comes up to operating speed.

Generator wattage required = (amps) x (volts) x (1, 2, or 3)

This example will help to explain these requirements.

A customer wants to operate the following equipment on a generator : (1) A Radiant Heater, (2) a Freezer, (3) a Small Refrigerator , (4) a Microwave Oven and (5) Four sixty-watt light bulbs.

Tools/Equipment	Nameplate Running Watts	Times(x) 1,2,3	Starting Watts
Radiant Heater	1,250	1	1,250
Freezer	400	3	1,200

SELECTING A GENERATOR

Small Refrigerator	400	3	1,200
Microwave Oven	750	1	750
4 Sixty-watt Light Bulbs	240	1	240
Total	3,840		4,640

A total of 4,640 starting watts are required if all the items were started simultaneously. This would require the use of generator with a minimum continuous rating of 5000 watts.

Typical equipment requirements

Appliance	Watts	Appliance	Watts
Light bulb	See bulb	Coffee makers	400-700
Clothes dryer	5000-10,000	Window fan	200
Iron(Hand)	500-1500	Radio	50-200
Portable heater	600-4800	Air conditioner (10,000BTU)	2000-3000
Toaster	900-1650	Automatic washer	150-1500
0-1/2 inch hand saw	1000-2500	Refrigerator	600-2000
Water heater	3000-5000	Television	100-500
Water pump	1000-3000	Vacuum cleaner	200-300
Sump pump	400-3000	Electric drill	225-100
Food freezer	300-500	Hot plate	330-1100

Electric motor loads

It is characteristic of common electric motors in normal operation to draw up to **six times** their running current while starting. The following table shows the watts required to start motors , however if an electric motor fails to start or reach running speed , turn off the appliance or tool immediately to avoid equipment damage. Always check the requirements of the tool or appliance being used compared to the rated output of the generator.

Motor size(HP)	Running watts	Watts required to start motor		
		Repulsion induction	Capacitor	Split phase
1/8	275	600	850	1200
1/6	275	600	850	2050
1/4	400	850	1050	2400
1/3	450	975	1350	2700
1/2	600	1300	1800	3600
3/4	850	1900	2600	
1	1100	2500	3300	

OPERATING VOLTAGE

! CAUTION

Operating voltage and frequency requirement of all electronic equipment should be checked prior to plugging them into the generator . Damage may result if the equipment is not designed to operate within a +/- 10% voltage variation , and +/- 2 Hz for frequency variation from the nameplate ratings. To avoid damage , always have an additional load plugged into the generator if solid state equipment (such as a personal computer) is used . A power line conditioner is recommended for some solid state applications .

A power line conditioner should be used when running one or more of the following solid state equipments:

Televisions

Personal computer

Copy machines

Telephone equipment

Kitchen appliances with digital displays

Garage door openers

Stereos

Quartz clocks

Other solid state equipment may require a power line conditioner.

INSTALLATION

! WARNING



To avoid possible personal injury or equipment damage , a registered electrician or an authorized service representative should perform installation and all service . Under no circumstances should an unqualified person attempt to wire into a utility circuit.

To avoid backfeeding into utility systems , isolation of the residence electrical system is required. Before temporary connection of the generator to the residence electrical system , turn off the main service/disconnect.

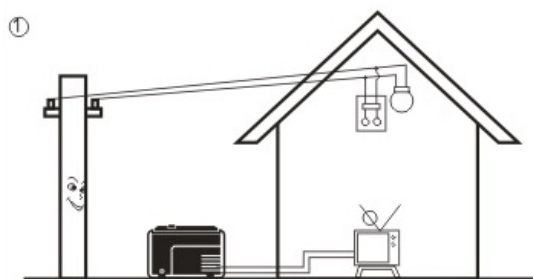

Correct



Incorrect

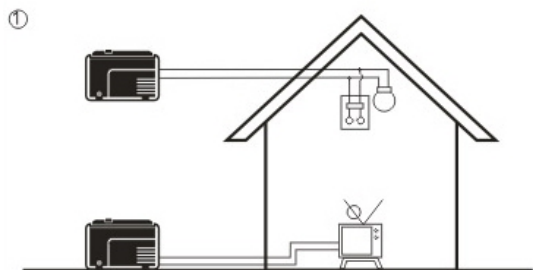

Correct

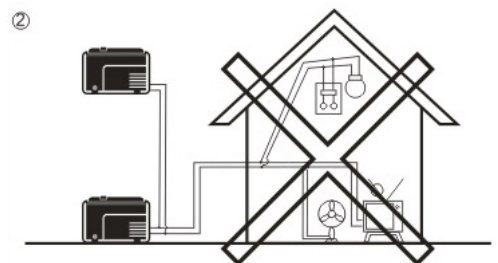

Incorrect

If your generator is to be used as a stand-by power source in case of utility power failure, it should be installed by a registered electrician and in compliance with all applicable local electrical codes.

Proper use requires that a double throw transfer switch be installed by a licensed qualified electrician so that the building's electrical circuits may be safely switched between utility power and the generator's output, thereby preventing backfeed into the power utility's electrical system.

! WARNING



To avoid backfeeding into utility systems, isolation of the residence electrical system is required. Before temporary connection of a generator to the residence electrical system turn off the main switch. Before making permanent connections a double throw transfer switch must be installed. To avoid electrocution or property damage,

only a trained electrician should connect generator to the residence electrical system. Local law may require isolation of the residence electrical system before connecting a generator to residence electrical systems. Temporary connection not recommended due to backfeeding.

Always follow local codes and regulations that apply to the installation of any item that concerns this product.

Extension cord

- Maximum recommended lengths(in feet)

Amps	Dia. 0.1285in (3.26mm) Wire	Dia. 0.1019in (2.59mm) Wire	Dia. 0.0808in (2.05mm) Wire	Dia. 0.0641in (1.63mm) Wire	Dia. 0.0508in (1.29mm) Wire
2.5		1000	600	375	250
5		500	300	200	125
7.5		350	200	125	100
10		250	150	100	50
15		150	100	65	
20	175	125	75	50	
25	150	100	60		
30	125	65			
40	90				

- This extension cord should be protected by a tough flexible rubber sheath (IEC 245) or the equivalent to withstand mechanical stresses.

Line transfer switch

If this generator is used for standby service, it must have a transfer switch between the utility power service and the generator . The transfer switch not only prevents the utility power from feeding into the generator, but it also prevents the generator from feeding into the utility company’s lines. This is intended to protect a serviceman who may be working on a damaged line. **THIS INSTALLATION MUST BE DONE BY A LINCENSED ELECTRICIAN AND ALL LOCAL CODES MUST BE FOLLOWED.**

PRE-OPERATION CHECK

Grounding

- Be sure to ground (earth) the generator.
- The ground terminal connected to the frame of the generator has been provided for grounding purpose.
- Be sure that the ground wire have sufficient current capacity.

(1) Ground wire diameter: 0.12 mm(0.005in) per ampere

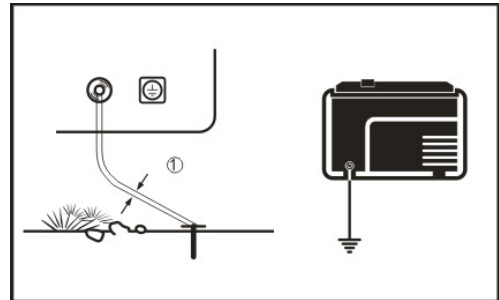

- The ground wire should be made of 0.1285in dia.(AWG#8) copper wire . Do not use wire with a higher gauge number . Higher gauge numbers indicate thinner wire , which may not provide an adequate ground path.
- Securely fasten the end terminal of the ground wire to the ground terminal on the generator frame.Tighten the lock nut on top of the ground wire end terminal. The other end of the ground wire must be securely fastened to an approved ground source. The examples given below illustrate a few of the ways in which a good ground source may be established .

A metal underground water pipe in direct contact with the earth for at least 10 feet canbe used as a grounding source. If an underground pipe is unavailable , an 8 foot length of pipe or rod may be used as the ground source . The pipe should be 3/4 inch diameter or larger and the outer surface must be noncorrosive . If a steel or iron rod is used it should be at least 5/8 inch diameter and if a nonferrous rod is used it should be at least 1/2 inch diameter and be listed as material for grounding. Drive the rod or pipe to a depth od 8 feet . If a rock bottom is encountered less than 4 feet down , bury the rod or pipe in a trench. All electrical tools and appliances operated from this generator , must be properly grounded by use of a third wire or be “ Double insulated “ .

It is recommended to:

1. Use electrical devices with 3 prong power cords .
 2. Use an extension cord with a 3 hole receptacle and a 3 prong plug at opposite ends to ensure continuity of the ground protection from the generator to appliance.
- For the approved ground sources, refer to the local laws and regulations . If not sure of regulations or procedures , obtain assistance from a qualified (licensed or certified) electrical technician.



WARNING



Do not use a pipe carrying combustible material as the ground source.

Lubrication

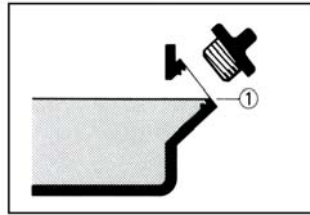
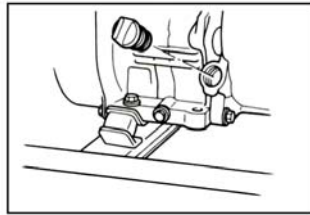
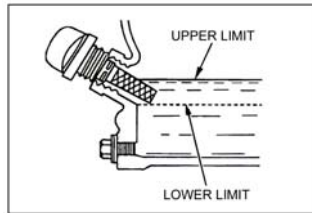
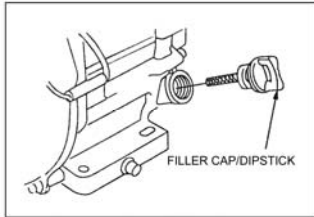

Do not attempt to start the engine without filling the crankcase with the proper amount and type of oil. **Your generator has been shipped from the factory without oil in the crankcase. Operating the generator without oil can damage the engine.**

Fill the engine with oil according to the operator manual. For units with a dipstick, fill oil to the proper level. Units without a dipstick should be filled to the top of the

opening of the oil fill (1). Do not over-fill. Do not screw the oil dipstick into the oil filler neck to check oil level.

Engine oil recommendations

- Oil is a major factor affecting performance and service life.
- Using 4-stroke automotive detergent oil. SAE 10W-30 is recommended for general use.
- Selecting the viscosity is based on the air temperature at the time of operation.
- Recommended engine oil classification: API service "SE" or higher grade

Low oil warning system

Most of generators are equipped with a low oil sensor. If the oil level becomes lower than required, the sensor will activate a warning device or stop the engine.

If the generator stops and the oil level is within specifications, check to see if generator is sitting at an angle that forces oil to shift. Place on an even surface to correct this. If engine fails to start, the oil level may not be sufficient to deactivate low oil level switch. Make sure the sump is completely full of oil.

Fuel recommendations

4-Stroke Engine

Using unleaded gasoline with a pump octane rating of 86 or higher. Unleaded gasoline produces fewer engine and spark plug deposits and extends exhaust system life. Never use stale or contaminated gasoline or an oil/gasoline mixture. Avoid getting dirt or water in the fuel tank.

Occasionally you may hear a light "spark knock" or "pinging" (metallic rapping noise) while operating under heavy loads. This is no cause for concern.

If spark knock or pingning occurs at a steady engine speed, under normal load, change brands of gasoline.

Notice:

Running the engine with persistent spark knock or pinging can cause engine damage. Running the engine with persistent spark knock or pinging is considered misuse.

2-Stroke Engine

Use oil-mixed gasoline. If not, engine will be overheated. Usually the gasoline and oil mixing ratio: 50:1

CAUTION

Do not overfill the tank. Keep maximum fuel level 1/4 inch below the top of the fuel tank or do not fill above the fuel strainer shoulder. This will allow expansion in hot weather and prevent overflow. Spilled fuel is not only a fire hazard, it causes environmental damage. Wipe up spills immediately. Refuel in a well-ventilated area before starting the engine. If the engine has been running, allow it to cool. After refueling, tighten the fuel tank cap securely. Fuel can damage paint and plastic.

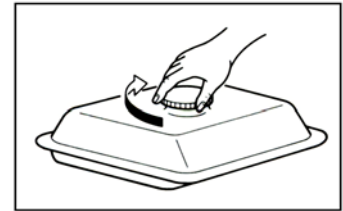
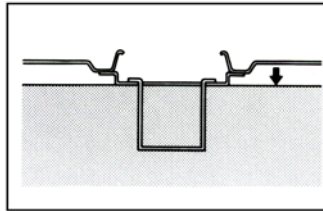

We recommend always using a fuel stabilizer. A fuel stabilizer will minimize the formulation of fuel gum deposits inside the carburetor during storage. The fuel stabilizer can be added to the gasoline in the fuel tank, or into the gasoline in a storage container.

START THE UNIT



WARNING



Gasoline is very dangerous. Serious injury or death may result from fire caused by

1. Do not fill fuel tank with engine running.
2. Do not spill fuel while refilling tank. (please use funnel for refilling)
3. For 4-stroke engine , do not mix oil with gasoline. For 2-stroke engine , please use oil-mixed gasoline.
4. Follow all instructions and warnings in the engine manual.

Pre-start preparation

Before starting the generator, check for loose or missing parts and for any damage which may have occurred during shipment or previous operation.



This generator must not be operated without all factory installed heat shields in place. Failure to comply may cause the fuel tank to overheat and result in personal injury from fire.

Start the engine

1. Check the oil level and fuel.
2. Disconnect all electrical loads from the unit.
3. Turn the engine switch to “ ON “ position (1).
4. Open fuel shut off valve (from “ OFF ” to “ ON “).
5. Adjust the choke of carburetor as necessary. (Note: usually the choke is put in the position (1) of full closing when cold starting , and will be opened or half opened while warm starting.)
6. Pull on the starter rope with fast steady pull. As the engine warms up, readjust the choke(1). On electric start models, turn the key switch to “START”. Release key switch after the engine starts.

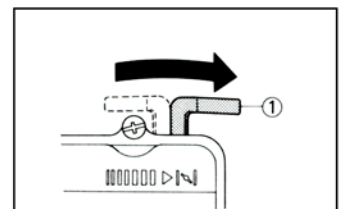
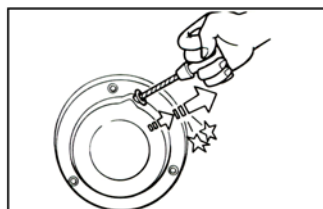
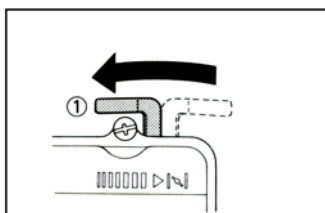
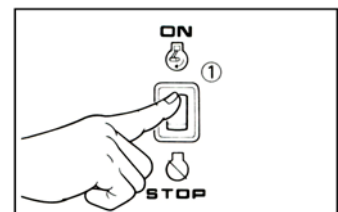
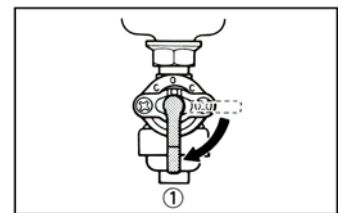

! DANGER



- Provide adequate ventilation for toxic exhaust gases and cooling air flow.
- Do not start or run the generator in an enclosed area, even if door or windows are open.
- Engines give off carbon monoxide, an odorless, colorless, poison gas.
- Breathing carbon monoxide can cause nausea, fainting or death.

! CAUTION

Allow generator to run at no load for 4 to 5 minutes upon each initial start-up to permit engine and generator to stabilize.

Applying load

- This unit has been pretested and adjusted to handle its full capacity. Before starting the engine, do not connect the electric apparatus. Apply load only after generator is running. Voltage is regulated via the engine speed adjusted at the factory for correct output. Do not readjust the engine speed.
- Wind the power output cord 2 or 3 turns around frame.

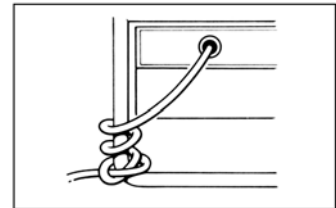

! CAUTION

- ▲ Be sure the total load is within generator rated output.
- ▲ Do not exceed the amperage rating of any one receptacle.
- ▲ Notice the power factor of load (see the “SELECTING A GENERATOR”)

Shutting the generator off

1. Remove entire electrical load.
2. Let the engine run for a few minutes at no load.
3. Move the engine switch to the “OFF” position (or “ STOP” position (1)).(Turn the key switch to “OFF” or “STOP” on electrical start models).
4. Do not leave the generator until it has completely stopped.
5. Close the fuel shut off valve if the engine is to be put in storage or

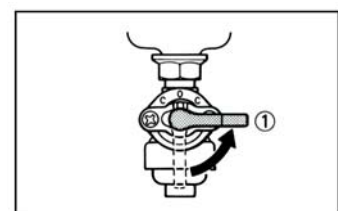
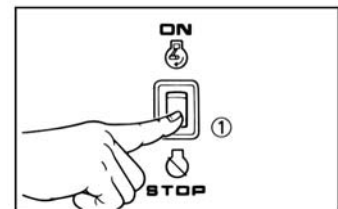

transported.

6. If cover is used, do not install until unit has cooled.

Break-in procedure

Controlled break-in helps insure proper engine and generator operation. Follow engine procedure outlined in engine manual.



CAUTION

- ▲ Do not apply heavy electrical load during break-in period (the first 2 to 3 hours of operations).

MAINTENANCE

Daily inspection

Before running the engine, check the following service items.

- Loose or broken bolts and nuts
- Clean air cleaner element
- Enough clean engine oil
- Leakage of gasoline and engine oil
- Enough gasoline
- Safe surroundings
- Excessive vibration, noise

Periodic inspection

Periodic maintenance is vital to the safe and efficient operation of your engine. Check the table below for periodic maintenance intervals.

PERIODIC MAINTENANCE						
ITEMS	NOTES	DAILY (Before operation)	INITIAL 20 hours	EVERY 50 hours	EVERY 100 hours	EVERY 300 hours
SPARK PLUG	Check condition. Adjust gap and clean. Replace if necessary.			◆		
ENGINE OIL	Check level	◆				
	Replace (*Note 1)		◆		◆	
AIR FILTER	Check	◆				
	Clean. Replace if necessary			◆		
FUEL FILTER	Clean fuel filter and fuel tank strainer. Replace if necessary				◆	
FUEL LINE	Check fuel hose for cracks or other damage. Replace if necessary.(* Note 2)	◆				
EXHAUST SYSTEM	Check for leakage. Retighten or replace gasket if necessary.	◆				
	Check muffler screen (spark arrester). Clean/replace if necessary.				◆	
VALVE CLEARANCE	Check and adjust when engine is cold. (* Note 2)					◆

COMBUSTION CHAMBER	Remove carbon from cylinder head. (* Note 2)					◆
FITTINGS / FASTENERS	Check. Replace if necessary.	◆				
CARBURETOR	Check choke operation	◆				
	Clean and adjust carburetor (* Note 2)					◆
STARTING SYSTEM	Check recoil starter operation	◆				
COOLING SYSTEM	Check fan damage.(* Note 2)					◆

* Note 1: Before changing oil, check for a suitable way to dispose of old oil. Do not pour it down into sewage drains, onto garden soil or into open streams. Your local zoning or environmental regulations will give you more detailed instructions on proper disposal.

* Note 2: These items should be serviced by your service dealer , unless you have the proper tools and mechanically professional.

It is also necessary for the user of the unit to conduct the maintenance and adjustments on the emission-related parts listed below to keep the emission control system effective. The emission control system consists of the following parts:

- Carburetor and internal parts
- Cold start enrichment system, if applicable
- Intake manifold, if applicable
- Air cleaner elements
- Spark plug
- Magneto or electronic ignition system
- Spark advance / retard system, if applicable
- Exhaust manifold , if applicable
- Fuel hoses , connectors and fuel tank cup

The maintenance schedule indicated in the above table is based on normal engine operation. Should the engine be operated in extremely dusty condition , in heavier loading condition or in commercial use, the maintenance intervals must be shortened depending on the contamination of oil , clogging of filter elements , wear of parts, and so on.

Inspecting the spark plug

Remove the spark plug and clean the electrodes section with a wire brush or sandpaper. Next , set the gap (1) at 0.028-0.031 inches (0.7-0.8mm) by adjusting the negative electrode. Replace the spark plug with correct torque : 14 ft-lb (20 N.m).

Note: Standard electrode color is tan color.

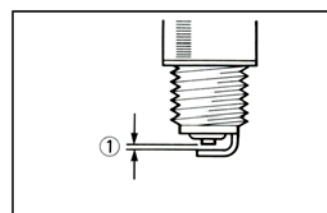
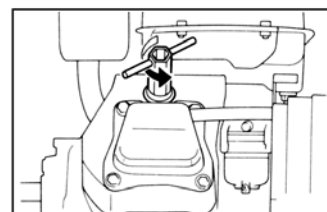

! CAUTION

- ▲ Replace with only the same type of spark plug which was removed. An improper spark plug can cause the engine to overheat, emit smoke, influence electromagnetic compatibility of generator or otherwise perform poorly.

Oil replacement

1. Change oil while engine is warm.
2. Place the generator unit on a level surface.
3. Remove the oil filler cap or dipstick (3).
4. Open the oil drain plug (1) and let oil drain completely into a pan placed under the engine.
5. Check gaskets (2). Replace if required.
6. Reinstall the oil drain plug and refill engine with clean oil.
7. Replace the oil filler cap or dipstick.

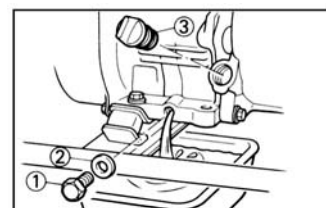

- ▲ Always use the best grade and clean oil. Contaminated oil, poor quality oil and shortage of oil cause damage to engine or shorten the engine life.

Air filter cleaning

A dirty air cleaner element will cause starting difficulty, power loss, engine malfunctions, and shorten engine life extremely. Always keep the air cleaner element clean.

1. Urethane foam element type

Remove the element and wash it in kerosene or diesel fuel. Then saturate it in a mixture of 3 parts kerosene or diesel fuel and 1 part engine oil. Squeeze the element to remove the mixture and install it in the air cleaner.

2. Dual element Type (Urethane foam and paper elements)

■ Urethane foam cleaning

Wash and clean the urethane foam with detergent. After cleaning, dry it.

Clean the urethane foam every 50 hours.

■ Paper element cleaning

Clean by tapping gently to remove dirt and blow off dust.

Never use oil. Clean the paper element every 50 hours of operation, and replace element set if required.

Note:

Clean and replace air cleaner elements more often when operating in dusty environments. Replace the element in case that dirt or dust can not be removed and / or that the element is deformed or deteriorated.

Fuel valve filter cleaning

1. Remove the cup at the bottom of the fuel valve with a small wrench.
2. Remove the fuel valve filter.
3. Clean and wash out the filter and cup and replace.

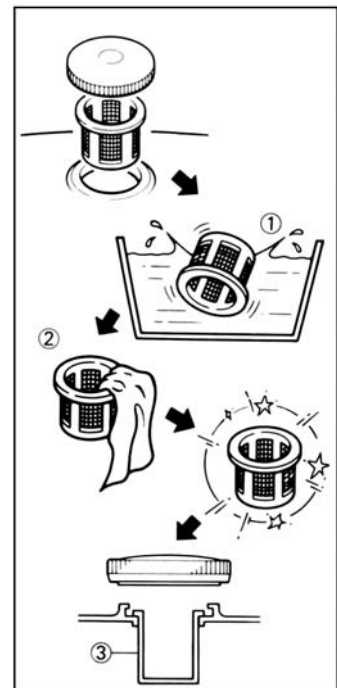
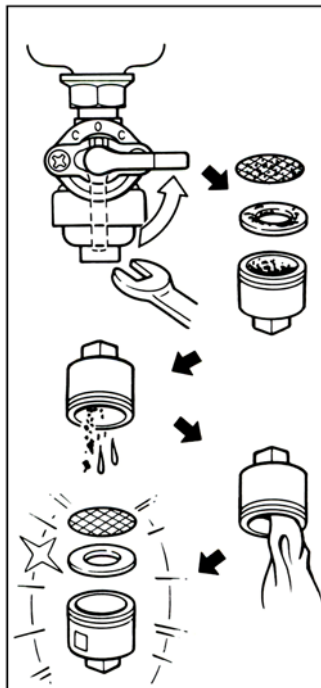

Fuel strainer cleaning

1. Remove the plastic fuel strainer, located below the fuel tank cap.
2. Wash the strainer in solvent (1) and replace (3).

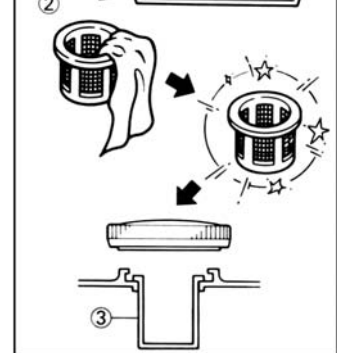
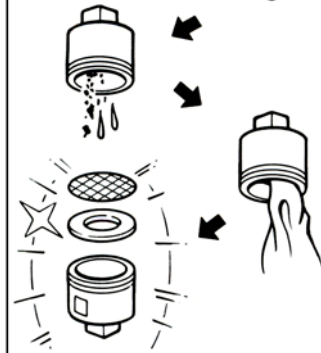

Generator

1. Brush type

The brushes in the generator should be inspected once every year for chips and cracks. Brushes should be replaced when they are over worn.

Note:

- Replace brushes in sets only, never separately.
- Replace only with brushes specified in parts list. Other brushes may appear to be identical but may have completely different mechanical and electrical characteristics.

2. Exciting the generator

■ Brush type

If there is a loss of residual magnetism (voltage will not build up), especially your unit has been sitting around for a long time period or due to vibration during shipping, it may be necessary to re-excite the unit.

This can be accomplished using a 6, 9-Volt lantern battery (dry cell) or a 12-Volt automotive battery. Disconnect all loads from generator. With the generator running, touch a lead connected from the positive battery terminal to the positive brush terminal, and a lead from the negative battery terminal to the negative brush terminal. The DC voltage fed through the rotor windings should restore magnetism. If the generator does not show any output after flashing the field, refer to the troubleshooting section for the generator.

Even if small permanent magnets are built into the rotors in order to insure the presence of a residual magnetic field. Occasionally, even these units will require flashing (re-exciting) due to the "permanent " magnet losing its magnetism.

■ Brushless type

Use a capacitor to re-excite the field (choose a capacitor with similar capacity). Firstly use 12-volt

battery to charge the capacitor , then touch two terminals of capacitor into the output receptacle with two wire leads to restore the magnetism.

Heat shield

Inspect to ensure that all heat shields and heat deflectors are intact and in place. Do not remove any parts or modify parts. Removing or modifying parts could cause serious damage to the unit.

Carburetor icing

During the winter, rare atmospheric conditions may develop which will cause an icing condition in carburetor. If this develops, the engine may run rough, loose power, and may stall. Contact your local dealer for more information.

Quick starting tips for units that have been sitting for awhile

If your unit has been sitting around for a long time period and is hard to start, try doing some of these easy steps.

1. Check the oil level. If too low, maybe low oil warning system function.
2. Replace the old fuel.
3. Change the spark plug.
4. Check the fuel lines. Make sure the fuel valve is open.
5. Check all generator parts for integrity.
6. Clean the carburetor.

SERVICE AND STORAGE

Infrequent service

If the unit is used infrequently, difficult starting may result. To eliminate hard starting, run the generator at least 30 minutes every month. Also , if the unit will not be used for some time , it is a good idea to drain the fuel from the carburetor and gas tank.

Long term storage

When the generator set is not being operated or is being stored more than one month, follow these instruction:

1. Replenish engine oil to upper level.
2. Drain gasoline from fuel tank (1), fuel line, fuel cock, and carburetor float bowl.
3. Pour a cup of clean engine oil in the tank (2), shake the tank (3)and then drain the excess oil (4).

4. Pour about one teaspoon of engine oil through the spark plug hole, pull the recoil starter several times and replace the plug. Then pull the starter until you feel the piston is on its compression stroke and leave it in that position. This closes both the intake and exhaust valves to prevent the inside of the cylinder from rusting.

5. Clean exterior of the generator and apply a rust inhibitor.

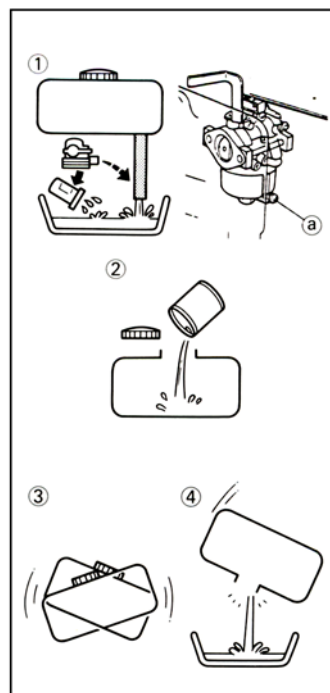

6. Cover the unit and store in a clean, dry place that is well ventilated away from open flame or sparks.

Note:

Using a fuel stabilizer is always recommended. A fuel stabilizer will minimize the formulation of fuel gum deposits during storage. The fuel stabilizer can be added to the gasoline in the fuel tank, or into the gasoline in a storage container.

TROUBLESHOOTING GUIDE

<i>Symptom</i>	<i>Possible Cause(s)</i>	<i>Corrective Action</i>
Zero output from receptacles	<ol style="list-style-type: none"> 1. Engine speed is too slow 2. Open or shorted wiring 	<ol style="list-style-type: none"> 1. Adjust engine speed 2. Clean and reconnect all wiring 3. Replace capacitor 4. Test winding resistance, replace winding if necessary 5. Test rectifier replace if necessary
Low output voltage with no load	<ol style="list-style-type: none"> 1. Engine speed is too slow 2. Open rectifier 3. Faulty capacitor 4. Open/shorted rotor or stator windings 5. Alternator not magnetized 	<ol style="list-style-type: none"> 1. Adjust engine speed 2. Test rectifier, replace if necessary 3. Replace capacitor 4. Test winding resistance, replace winding if necessary 5. Re-magnetize the alternator
High output voltage with no load	<ol style="list-style-type: none"> 1. Faulty capacitor 2. Engine speed is too fast 	<ol style="list-style-type: none"> 1. Replace capacitor 2. Adjust engine speed
Low output voltage under load	<ol style="list-style-type: none"> 1. Open rectifier 2. Engine speed too low at full load 3. Excessive load applied 	<ol style="list-style-type: none"> 1. Test rectifier, replace if necessary 2. Adjust engine speed 3. Reduce the applied load
Erratic output voltage	<ol style="list-style-type: none"> 1. Dirty, corroded, or loose wiring connection 2. Unbalanced load applied 	<ol style="list-style-type: none"> 1. Referring to the wiring diagram, clean and reconnect all wiring 2. Remove all loads, then apply each one individually to determine which one is causing erratic function
Noisy operation	<ol style="list-style-type: none"> 1. Loose generator or engine bolt 2. Short circuit in generator field or load 3. Faulty bearing 	<ol style="list-style-type: none"> 1. Tighten all mountings 2. Test winding resistance, replace field winding if necessary Test load devices for shorts. Replace defective load device 3. Replace bearing
Engine won't start	<ol style="list-style-type: none"> 1. No fuel 2. Fuel switch is in closed position 3. Engine switch is in closed position 4. Spark plug dirty or wrong gap 5. No enough compression inside the cylinder 6. battery discharged 	<ol style="list-style-type: none"> 1. Check fuel 2. Place fuel switch in open position 3. Place engine switch in open position 4. Clean spark plug. Adjust gap, replace if necessary. 5. Check leakage from the cylinder 6. Recharge the battery

LIMITED WARRANTY

1. **DURATION :** One (1) year from the date of purchase by the original purchaser (retail customer) on products used solely for consumer applications; if a product is used for business, commercial, or industrial applications, the warranty period will be limited to ninety (90) days from the date of purchase.
 2. **WHO GIVES THIS WARRANTY (WARRANTOR):**
SUMEC Machinery & Electric Co., Ltd. (SUMEC)
 3. **WHO RECEIVES THIS WARRANTY(PURCHASER):**
The original purchaser (other than for purposes of resale) of the Warrantor’s generator.
 4. **WHAT PRODUCTS ARE COVERED BY THIS WARRANTY:**
Any portable generator supplied or manufactured by Warrantor.
 5. **WHAT IS COVERED UNDER THIS WARRANTY:**
Substantial defects on material and workmanship which occur within the duration of the warranty period.
 6. **WHAT IS NOT COVERED UNDER THIS WARRANTY:**
 - A. Transportation changes for sending the product to Warrantor or its authorized service representative for warranty service, or for shipping repaired or replacement products back to the customer; these charges must be borne by the customer.
 - B. Damages caused by abuse, accident, shipping, misuse, overloading, modification, and the effects of corrosion, erosion and normal wear and tear.
 - C. Warranty is voided if the customer fails to install , maintain and operate the product in accordance with the instructions and recommendations set forth in the owner's manual(s), or if the product is used as rental equipment.
 - D. Pre-delivery service, i.e. assembly, oil or lubricants, and adjustment.
 - E. Items or service that are normally required to maintain the product, i.e. lubricants and filters.
 - F. Warrantor will not pay for repairs or adjustments to the product, or for any costs or labour, performed without Warrantor ’s prior authorization.
- EXCLUSIONS AND LIMITATIONS :** Warrantor makes no other warranty of any kind, express or implied. Implied warranties, including warranties of merchantability and of fitness for a particular purpose, are hereby disclaimed. This warranty service described above is the exclusive remedy under this warranty; liability for incidental and consequential damages is excluded to the extent permitted by law.
7. **RESPONSIBILITIES OF PURCHASER UNDER THIS WARRANTY:**
 - A. The purchaser must provide dated proof of purchase and must notify Warrantor within the warranty period.
 - B. Deliver or ship the serviced generator or component to the nearest Warrantor’s authorized service representative. Freight costs, if any, must be borne by the purchaser.

Warranty Card	
FIRMAN GASOLINE ENGINE GENERATOR	
Model:	_____
ID No.:	_____
Serial No.:	_____
Date of Purchase:	_____
Dealer’s stamp and signature:	_____ Customer’s signature: _____